

# Pörgő

## Rotor

Model: Peter Budai © 2000.  
Diagrams: Peter Budai © 2000.

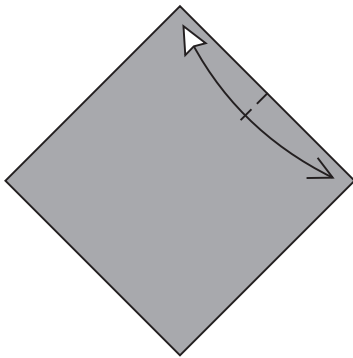
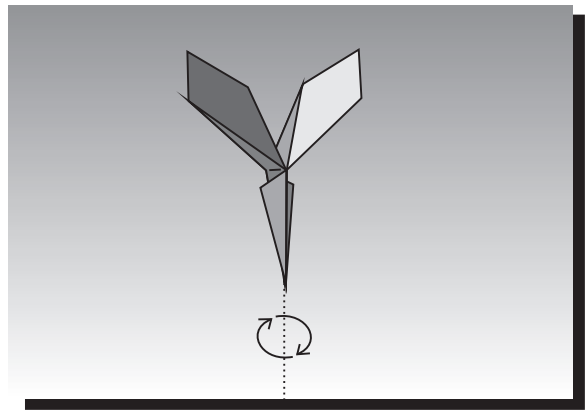

1. Oda-visszahajtás.  
*Fold and unfold.*

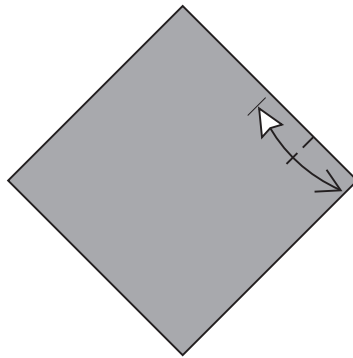

2. Oda-visszahajtás.  
*Fold and unfold.*

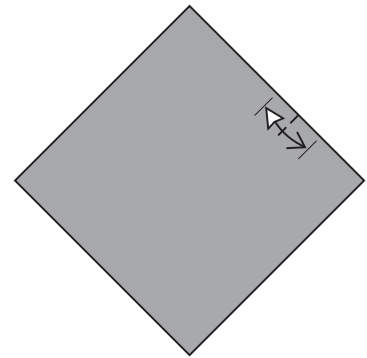

3. Oda-visszahajtás.  
*Fold and unfold.*

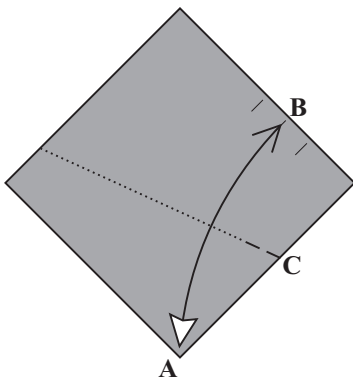

4. A-t a B-hez hajtjuk, és vissza.  
*Fold A to B and unfold.*

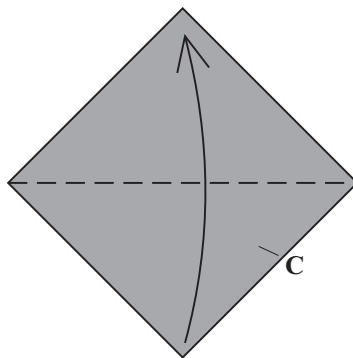

5. Félbehajtottunk.  
*Fold in half.*

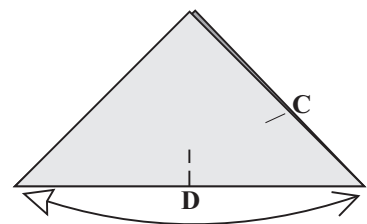

6. Oda-visszahajtás.  
*Fold and unfold.*

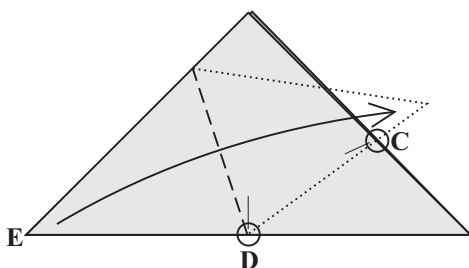

7. Felhajtjuk az E csücsöt úgy, hogy a DE él átmenjen a C ponton...  
*Fold up corner E so that edge DE will hit point C...*

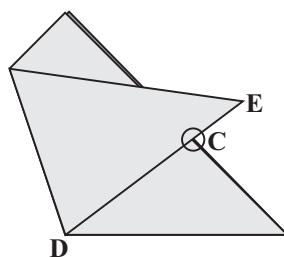

8. ...így. Fordítsd meg!  
*...like this. Turn over.*

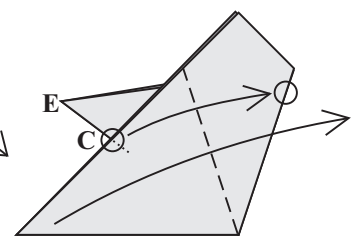

9. Úgy hajtunk, mint a 7. lépésben.  
*Fold similarly to step 7.*

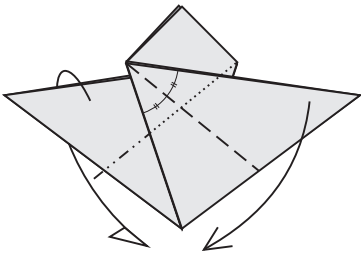

**10.** A szögfelező mentén hajtunk elől és hátul.  
*Fold angle bisector. Repeat behind.*

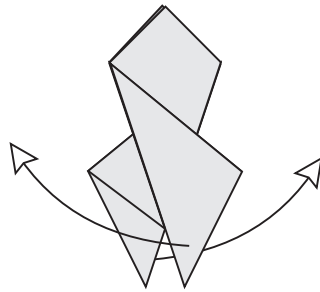

**11.** Visszahajtjuk a 7. lépésig.  
*Unfold to step 7.*

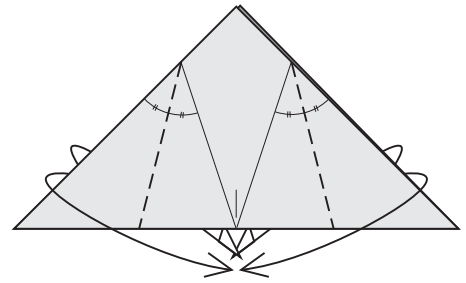

**12.** Váltóhajtás kifelé a kész élek felhasználásával.  
*Outside-reverse-fold on existing creases.*

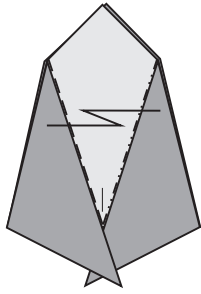

**13.** Redőzés a kész élek felhasználásával.  
*Pleat using existing creases.*

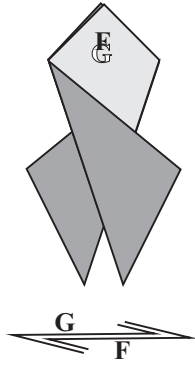

**14.** Előrehúzzuk a hátsó réteget...  
*Bring the back layer to the front...*

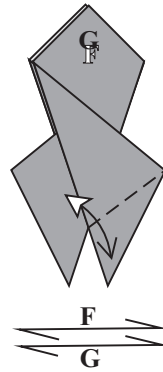

**15.** ... így. Oda-visszahajtás.  
*...like this. Fold and unfold.*

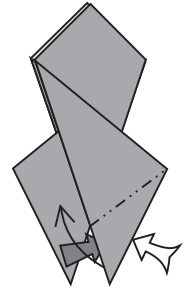

**16.** Váltóhajtás.  
*Reverse-fold.*

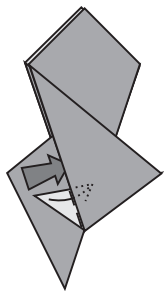

**17.** A kis fehér fület behajtjuk a zsebbe.  
*Fold the little white flap into the pocket.*

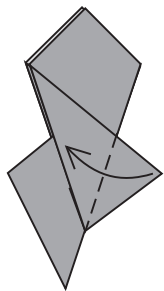

**18.** Szögfelezőt hajtunk.  
*Fold angle bisector.*

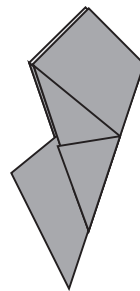

**19.** Fordítsd meg!  
*Turn over.*

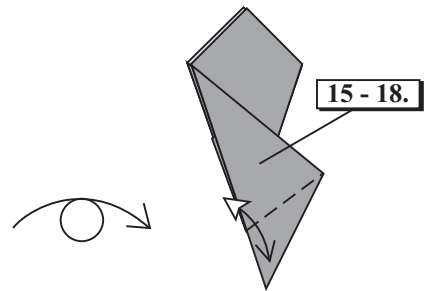

**20.** Ismételj 15-18-ig!  
*Repeat steps 15-18.*

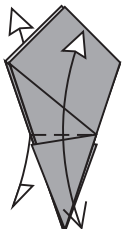

**21.** Oda-visszahajtás (élezzük le erősen). Ismételjük hátul is!  
*Fold and unfold (crease firmly). Repeat behind.*

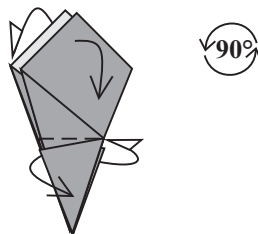

**22.** Nyissuk szét a négy fület! Forgassuk el 90 fokkal!  
*Open the four flaps. Rotate 90 degrees.*

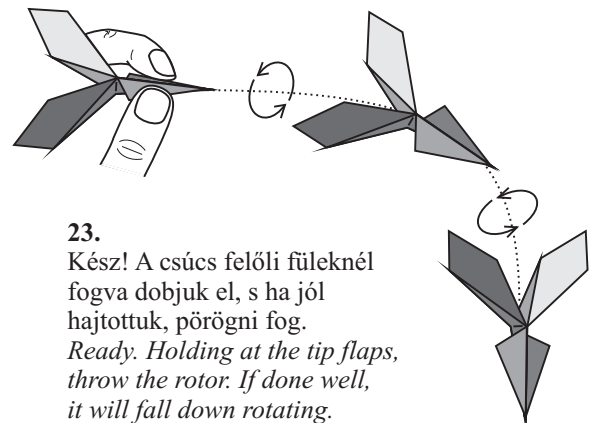

**23.** Kész! A csúcs felőli füleknél fogva dobjuk el, s ha jól hajtottuk, pörögni fog.  
*Ready. Holding at the tip flaps, throw the rotor. If done well, it will fall down rotating.*